

Gulliver LALALA Tour, Tech Rider Jan. 2008

Patch	Channel	Instrument	Mic/DI	Notes / Mik Stands	Insert
	1	Kick	B91	-	Gate
	2	Kick Sub	Beta52	Short	Gate
	3	Snare 1 Top	SM57 / Beta 57A	Short / Clamp	
	4	Snare 1 Btm	SM57 / Beta 57A	Short / Clamp	Gate
	5	Hi Hat	Cond.	Short	
	6	Rack Tom	B98/e504/etc.	-	Gate
	7	Rack Tom	B98/e504/etc.	-	Gate
	8	Floor Tom	B98/e504/etc.	-	Gate
	9	E-Bass	Build in DI	-	Comp
	10	Git Engel L	Sm 57	Short	
	11	Git Engel R	Sm 57	Short	
	12	Git Fender L	Sm 57	Short	
	13	Git Fender R	Sm 57	Short	
	14	Submixer L	Symmetric Jack Out	Jack – XLR adapter oder DI	Comp
	15	Submixer R	Symmetric Jack Out	Jack – XLR adapter oder DI	Comp
	16	Vox Background	DI (FX Inserted)	Long	Comp
	17	Vox Lead 1 Atto	Sm 58 / Beta 58	Long	Comp
	18	Vox Lead 2 Hönta	Sm 58 / Beta 58	Long	Comp
	19	FX 1 L	(At least Two <u>quality</u> FX Units needed)		
	20	FX 1 R	TC MPX 2000/3000/4000 etc / m.one		
	21	FX 2 L	Yamaha SPX 90 / 990		
	22	FX 2 R			
	23	TAP DELAY	TC D-two or 2290.		
	24	Talkback	Anything with a switch		

Overheads not needed, our Drummer sings. **Drums must be in front!**

- We need at least a good 4 way monitoring with a minimum of 5 Wedges.
- Quality PA & Mixer with at least 24 Ch, with parametric (!) EQ's and at least 8 Aux.
- 6 Gates, 6 Comps, 2 Multi FX and a Tap Delay. 1 CD Player

STAGEPLOT GULLIVER

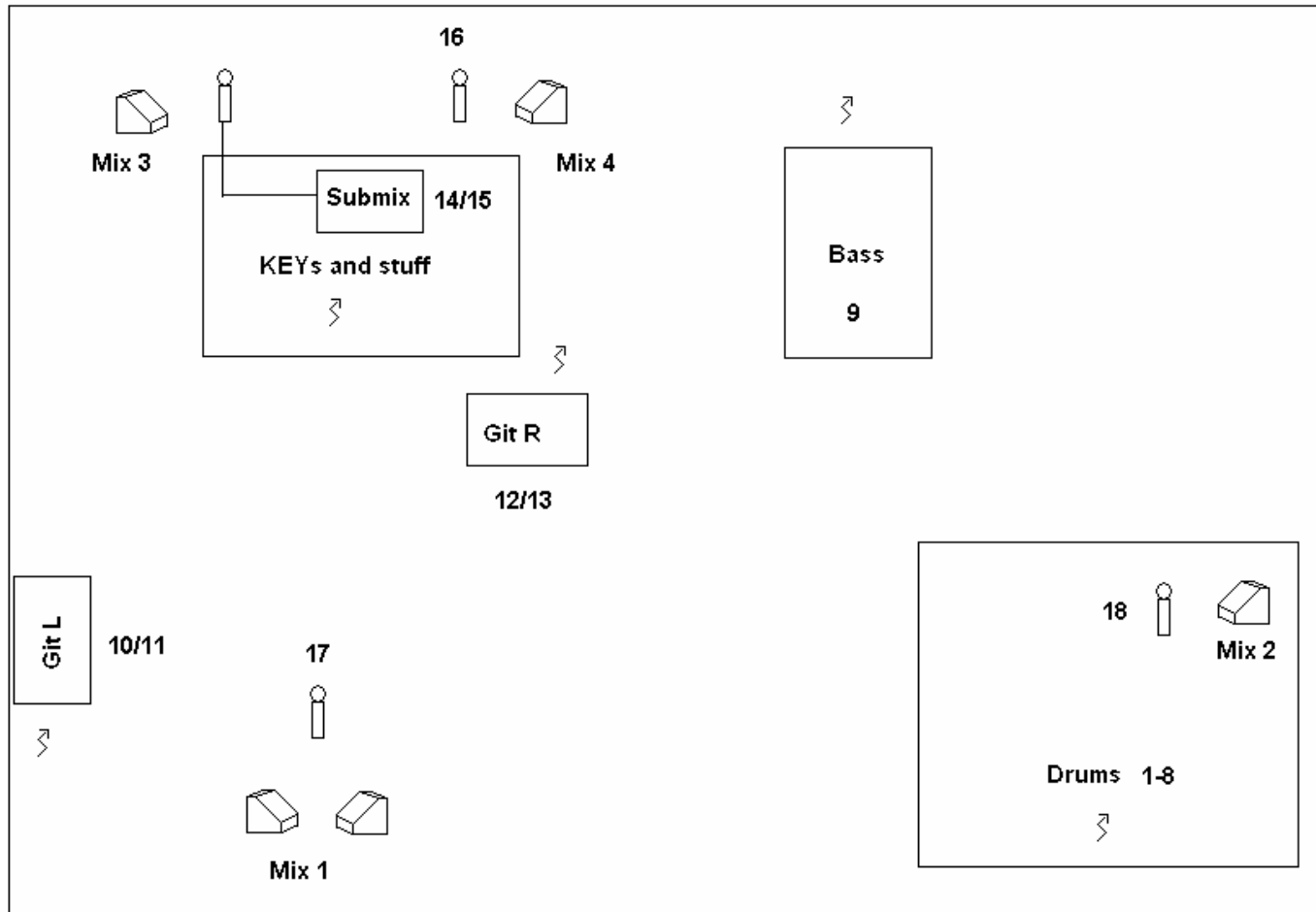

Booking: Thom Businger
Foh Mix: Till Dudda

thom@08eins.ch
till@frontofhouse.ch

+41 (0)78 772 92 22
+41 (0)79 479 47 90